



**US Army Corps  
of Engineers®**  
Engineer Research and  
Development Center



Environmental Quality and Installations (EQI) Research Program

## **Modeling Firing Range Best Management Practices with TREECS™**

Mark S. Dortch, Billy E. Johnson, and Jeffrey A. Gerald

June 2013

**The US Army Engineer Research and Development Center (ERDC)** solves the nation's toughest engineering and environmental challenges. ERDC develops innovative solutions in civil and military engineering, geospatial sciences, water resources, and environmental sciences for the Army, the Department of Defense, civilian agencies, and our nation's public good. Find out more at [www.erdcenter.usace.army.mil](http://www.erdcenter.usace.army.mil).

To search for other technical reports published by ERDC, visit the ERDC online library at <http://acwc.sdp.sirsi.net/client/default>.

# **Modeling Firing Range Best Management Practices with TREECS™**

Mark S. Dortch

*Los Alamos Technical Associates, Inc.  
999 Central Avenue, #300  
Los Alamos, NM 87544*

Billy E. Johnson and Jeffrey A. Gerald

*Environmental Laboratory  
U.S. Army Engineer Research and Development Center  
3909 Halls Ferry Road  
Vicksburg, MS 39180-6199*

Final report

Approved for public release; distribution is unlimited.

## Abstract

The Training Range Environmental Evaluation and Characterization System (TREECS™) is being developed for the Army with varying levels of capability to forecast the fate of and risk from munitions constituents (MC), such as metals and high explosives (HE), within and transported from firing/training ranges to surface water and groundwater. The overall objective is to provide environmental specialists with tools to assess the potential for migration of MC into surface water and groundwater systems and to assess range management strategies to protect human and environmental health. TREECS™ can be used to assess best management practices (BMPs) for military ranges to avoid, reduce, and remediate MC concentrations in receiving waters. This report describes how TREECS™ can be used to assess range BMPs. New TREECS™ modules are being developed to address some of the BMPs. The formulation, testing, and TREECS™ implementation strategies of these new modules are also presented in this report.

**DISCLAIMER:** The contents of this report are not to be used for advertising, publication, or promotional purposes. Citation of trade names does not constitute an official endorsement or approval of the use of such commercial products. All product names and trademarks cited are the property of their respective owners. The findings of this report are not to be construed as an official Department of the Army position unless so designated by other authorized documents.

**DESTROY THIS REPORT WHEN NO LONGER NEEDED. DO NOT RETURN IT TO THE ORIGINATOR.**

# Contents

|  |             |
|--|-------------|
| <b>Abstract</b> .....  | <b>ii</b>   |
| <b>Figures and Tables</b> .....                                  | <b>v</b>    |
| <b>Preface</b> .....   | <b>vi</b>   |
| <b>Unit Conversion Factors</b> .....                             | <b>vii</b>  |
| <b>List of Acronyms, Abbreviations, and Symbols</b> .....        | <b>viii</b> |
| <b>1 Introduction</b> .....                                      | <b>1</b>    |
| Background .....   | 1           |
| Objectives .....   | 2           |
| Scope .....  | 3           |
| <b>2 BMP Assessments with the Original Form of TREECS™</b> ..... | <b>4</b>    |
| Background .....   | 4           |
| Source loading management .....                                  | 4           |
| Source treatment .....   | 5           |
| Down-gradient receiving water treatment.....                     | 7           |
| <b>3 Source Removal</b> .....                                    | <b>8</b>    |
| Background .....   | 8           |
| Model modifications for soil removal.....                        | 8           |
| Model modifications for burning .....                            | 10          |
| Model modifications for phytoextraction.....                     | 10          |
| UXO removal .....  | 11          |
| TREECS™ implementation.....                                      | 12          |
| <b>4 Reactor Model for MC Degradation</b> .....                  | <b>14</b>   |
| Background .....   | 14          |
| Model formulation.....   | 15          |
| Example solutions .....  | 16          |
| Inputs and outputs.....  | 17          |
| <b>5 Sedimentation Basin Model for MC Removal</b> .....          | <b>22</b>   |
| Background .....   | 22          |
| Model formulation.....   | 22          |
| Example solutions .....  | 23          |
| Inputs and outputs.....  | 25          |
| <b>6 Implementation of New Modules within TREECS™</b> .....      | <b>28</b>   |
| New input tabs for the soil model UI.....                        | 28          |
| Joint use of degradation reactor and sedimentation basin.....    | 29          |

**References.....31**

**Report Documentation Page**

# Figures and Tables

## Figures

|  |    |
|--|----|
| Figure 1. Dimensionless MC exit concentration as affected by degradation rate and $K_{dr}$ .....                                 | 17 |
| Figure 2. Schematic of reactor types and their interactions with input and output files associated with the soil model UI.....   | 18 |
| Figure 3. Removal efficiency of lead for sedimentation basin as related to hydraulic loading rate and TSS settling rate. ....    | 25 |
| Figure 4. Schematic of sedimentation basin model interactions with input and output files associated with the soil model UI..... | 26 |
| Figure 5. Sedimentation basin and reactor model interactions with input and output files associated with the soil model UI.....  | 30 |

## Tables

|  |    |
|--|----|
| Table 1. Fraction of MC dissolved in water as related to TSS and $K_d$ .....   | 14 |
| Table 2. Inputs for example application of the sedimentation basin model. .... | 24 |

## Preface

This study was funded by the U.S. Army's Environmental Quality and Installations (EQI) Research Program. The work reported herein was conducted by staff within the Water Quality and Contaminant Modeling Branch (WQCMB), Environmental Processes and Effects Division (EPED), Environmental Laboratory (EL), of the U.S. Army Engineer Research and Development Center (ERDC). The WQCMB staff that conducted this work and prepared this report included the following: Dr. Mark Dortch of MSD Engineering Consulting under contract to Los Alamos Technical Associates, which was under contract to ERDC; and Dr. Billy Johnson and Jeffrey Gerald of the WQCMB.

The study was conducted under the general direction of Dr. Beth Fleming, Director, EL; Dr. Jack Davis, Deputy Director, EL; Dr. Warren Lorentz, Chief, EPED; and Dr. Dorothy Tillman, acting Chief, WQCMB. Dr. Elizabeth Ferguson was Technical Director for Military Materials in the Environment, and John Ballard was Program Manager for the EQI Research Program.

Dr. Jeffery P. Holland was Director of ERDC. COL Kevin Wilson was Commander. This report is approved for unlimited distribution.



## Unit Conversion Factors

| Multiply             | By         | To Obtain     |
|----------------------|------------|---------------|
| acres                | 4,046.873  | square meters |
| feet                 | 0.3048     | meters        |
| miles (U.S. statute) | 1,609.347  | meters        |
| pounds mass          | 453.59     | grams         |
| English tons         | 907.2      | kilograms     |
| slugs                | 14.59390   | kilograms     |
| square feet          | 0.09290304 | square meters |

# List of Acronyms, Abbreviations, and Symbols

## Acronyms and Abbreviations

|         |  |
|---------|--|
| AOI     | area of interest, such as HE impact area                             |
| BMP(s)  | best management practice(s)  |
| DoD     | Department of Defense  |
| EL      | Environmental Laboratory   |
| EPED    | Environmental Processes and Effects Division                         |
| ERDC    | Engineer Research and Development Center                             |
| EQI     | U.S. Army's Environmental Quality and Installations Research Program |
| HE      | high explosives  |
| MC      | munitions constituents, such as metals and HE                        |
| PRB     | permeable reactive barrier   |
| RDX     | Research Department Explosive, a high explosive                      |
| TREECS™ | Training Range Environmental Evaluation and Characterization System  |
| trp     | File extension for a TREECS™ project application file                |
| TSS     | total suspended solids concentration                                 |
| UXO     | unexploded ordnance  |
| WFF     | water flux file used in TREECS™                                      |
| WQCMB   | Water Quality and Contaminant Modeling Branch                        |

## Mathematical Symbols

|       |  |
|-------|--|
| $A$   | surface area of AOI, square meters   |
| $A_b$ | surface area of a sedimentation basin, square meters   |
| $BCR$ | bioconcentration ratio, milligrams MC in plant/kilogram plant / milligram MC in soil/kilogram soil (dimensionless), where all mass is dry mass |

|              |  |
|--------------|--|
| $B_R$        | AOI burn rate for source removal, acres/year   |
| $C$          | MC concentration in the reactor pore water, milligrams/liter   |
| $C_i$        | dissolved MC concentration in water entering the reactor, milligrams/liter   |
| $C_L$        | dissolved MC concentrations in water exiting the reactor, milligrams/liter   |
| $C_T$        | MC total (dissolved and particulate) concentration in water within and exiting a sedimentation basin, milligrams/liter   |
| $C_{Ti}$     | total (dissolved and particulate) influent MC concentration for degradation reactor and sedimentation basin, milligrams/liter  |
| $C_{tt}$     | total (particulate, dissolved, and vapor) non-solid phase MC concentration within the soil matrix on a total volume basis, grams/cubic meter                                     |
| $D_x$        | dispersion coefficient in the reactor flow, square meters/day  |
| $E$          | AOI soil erosion rate, meters/day or meters/year   |
| $F_c$        | combined surface water MC flux from AOI including soil interflow if that option is chosen, grams/day or grams/year   |
| $F_{dis}$    | solid phase MC dissolution flux, grams/year  |
| $F_{dp}$     | factor used to convert from total concentration on a total volume basis to dissolved concentration in the porous media on a total volume basis for the soil model, dimensionless |
| $F_d$        | fraction of MC total concentration in water that is in dissolved form, dimensionless   |
| $F_e$        | MC flux leaving AOI due to soil erosion, grams/year  |
| $F_{es}$     | erosion flux of solid phase MC particles, grams/year   |
| $F_i$        | soil interflow MC flux, grams/year   |
| $F_l$        | MC leaching flux from AOI, grams/year  |
| $F_p$        | fraction of MC total concentration in water that is particulate form, dimensionless  |
| $F_{precip}$ | precipitation flux due to dissolved pore water MC concentration within AOI exceeding the MC water solubility limit, grams/year   |

|           |  |
|-----------|--|
| $F_r$     | runoff MC flux from AOI, grams/year  |
| $F_{sbd}$ | dissolved MC flux exiting a sedimentation basin, grams/day or grams/year   |
| $F_{sbp}$ | particulate MC flux exiting a sedimentation basin, grams/day or grams/year   |
| $F_{tp}$  | influent MC flux of a degradation reactor that is in particulate form and must be added back to the untreated fluxes, grams/day or grams/year  |
| $f_H$     | fraction of the plant production rate that is harvested during phytoextraction, dimensionless  |
| $f_T$     | fraction of plant uptake (bioaccumulation) of MC that is transformed, dimensionless  |
| $f_t$     | fraction of total flow from AOI to surface water that is treated by a degradation reactor and/or sedimentation basin; fraction of total flow from AOI to vadose zone that is treated by a degradation reactor, dimensionless |
| $G$       | plant production rate, kilograms dry plant mass/square meters-year   |
| $H_r$     | reactor dimension (e.g., depth) perpendicular to flow axis, meters   |
| $K_d$     | distribution coefficient for partitioning an MC between soil particles and water, liters/kilogram  |
| $K_{dr}$  | distribution coefficient for partitioning an MC between reactor media and water, liters/kilogram   |
| $K_{dw}$  | distribution coefficient for partitioning an MC between water and solids suspended in water, liters/kilogram   |
| $K_{ow}$  | MC octanol-water partition coefficient, milligrams/cubic meter octanol/ milligrams/cubic meter water   |
| $L_r$     | length of the reactor along the flow axis, meters  |
| $L(t)$    | time-varying solid phase MC mass loading, grams/year   |
| $M_s$     | solid phase MC mass, grams   |
| $Q$       | water flow rate through a degradation reactor or sedimentation basin, cubic meters/day or cubic meters/year  |

|             |   |
|-------------|---|
| $Q_i$       | soil interflow flow rate, cubic meters/day or cubic meters/year   |
| $Q_r$       | overland runoff flow rate, cubic meters/day or cubic meters/year  |
| $Q_T$       | total water flow rate from AOI to surface water (including soil interflow if this option is chosen) or vadose zone, cubic meters/day or cubic meters/year |
| $R$         | reactor retardation factor, dimensionless   |
| $RE$        | removal or trapping efficiency of a sedimentation basin to remove contaminants from the influent, percent   |
| $R_{ns}$    | non-solid phase MC source or inventory removal rate, year <sup>-1</sup>   |
| $R_s$       | MC source or inventory removal rate, year <sup>-1</sup>   |
| $SR$        | MC mass selective removal rate, grams/year  |
| $T_{1/2}$   | half-life due to decay or degradation, year   |
| $TSS$       | total suspended solids concentration within and exiting a sedimentation basin, milligrams/liter   |
| $TSS_i$     | total suspended solids concentration of the influent to a reactor or sedimentation basin, milligrams/liter  |
| $t$         | time, year or day   |
| $U$         | Darcy transit speed through the reactor, meters/day   |
| $V_b$       | volume of water in a sedimentation basin, cubic meters  |
| $v_s$       | settling rate of suspended solids in a sedimentation basin, meters/day  |
| $W_r$       | reactor dimension (e.g., width) perpendicular to flow axis, meters  |
| $x$         | distance along the flow axis of a degradation reactor, meters   |
| $Z_b$       | surficial soil layer thickness of AOI, meters   |
| $\lambda$   | first-order degradation rate of MC, time <sup>-1</sup>  |
| $\lambda_r$ | first-order degradation rate of MC within reactor, day <sup>-1</sup>  |
| $\lambda_d$ | degradation rate for dissolved MC, day <sup>-1</sup>  |
| $\lambda_p$ | degradation rate for MC adsorbed to reactor material, day <sup>-1</sup>   |
| $v$         | pore water velocity in the reactor flow, meters/day   |

---

|             |  |
|-------------|--|
| $\phi$      | AOI soil porosity, fraction  |
| $\phi_r$    | porosity of the reactor media, fraction  |
| $\rho_b$    | soil dry bulk density, grams/cubic centimeter or kilograms/liter, grams/cubic meter, and kilograms/cubic meter |
| $\rho_{br}$ | dry bulk density of the reactor media, kilograms/liter   |

# 1 Introduction

## Background

There has been increased interest in managing Department of Defense (DoD) firing and training ranges for protection of human health and the environment against exposure to munitions constituents (MC), such as high explosives (HE) and metals. Range management for environmental compliance, referred to here as Best Management Practices (BMPs), can include range use strategies as well as remediation. Jenkins and Vogel (2012 draft) conducted a review of BMPs for operational ranges. Based upon their review, it appears that military range BMPs for MC reduction generally fall under the following five broad categories:

1. Source loading management: reduce loadings to the area of interest (AOI)
2. Source removal: remove MC mass from the AOI
3. Source treatment: treat MC mass within the AOI to reduce export from the AOI
4. AOI exit treatment: treat AOI MC export fluxes as they exit the AOI
5. Down-gradient receiving water treatment: treat MC export fluxes within down-gradient receiving waters

Examples of an AOI include the impact area of fired medium- and large-caliber munitions, firing points, impact berms for small arms ranges, demolition sites, grenade ranges, etc.

Source loading management can involve rotating range use over time, or simply varying the numbers and/or types of items fired each year. The second BMP category, source removal, can involve such things as soil excavation/removal and controlled burning on the landscape. Phytoremediation can fall in the second category when plants that bioaccumulate MC are removed. The third BMP category, source treatment, involves treatment technologies within the AOI that more fully sequester MC in AOI soil, such as soil amendments that reduce metal solubility and dissolution (Larson et al. 2007), or that enhance MC degradation, such as adding hydrated lime for alkaline hydrolysis of high explosives (Larson et al. 2008, Gent et al. 2010). In both cases, the export of MC from the AOI is reduced.

Phytoremediation can also be considered a source treatment BMP when plants uptake and transform the MC into other chemical forms that are less

harmful. The fourth BMP category is referred to as AOI exit treatment since it addresses MC removal after it leaves the AOI and before reaching down-gradient receiving waters. Examples of this category include permeable reactive barriers (PRBs), detention ponds, buffer strips, and similar methods to remove MC before transport to off-site receiving waters. Down-gradient receiving water treatment refers to MC removal within off-site waters. This fifth category can include treatment with various types of surface waters, such as wetlands, ponds, lakes, and streams, as well as groundwater remediation.

The Training Range Environmental Evaluation and Characterization System (TREECS™) has been developed by the U.S. Army Engineer Research and Development Center (ERDC) for the U.S. Army with varying levels of capability to forecast the fate of MC within and transported from firing and training ranges to surface water and groundwater. The overall purpose of TREECS™ is to provide environmental specialists with tools to assess the potential for MC migration into surface water and groundwater systems and to assess military range management strategies to ensure protection of human health and the environment.

The initial focus of TREECS™ was predicting if and when range use could pose problems regarding MC export to receiving waters. More recently, an emphasis has been placed on the use of TREECS™ for assessing range BMPs. The purpose of this report is to provide an overview of the approaches that can be used or developed within TREECS™ for modeling the effects of various range management and remediation strategies to reduce MC concentrations in the environment.

## **Objectives**

The objectives of this study and report are to develop and present formulations and implementation approaches for modeling various BMPs within all five BMP categories. Some of the modeling approaches require model development. Some of this model development was completed during the course of publishing this report, while other development had not been completed. For consistency, this report uses the present tense when referring to model development regardless of the development status at the time of this publication. Thus, this report also serves as a guide for BMP model software development and implementation.



## Scope

This report describes how TREECS can be used to assess military range BMPs. The next chapter discusses how TREECS™ can be used in its original form (before adding BMP modules) for addressing BMPs that fall under categories 1, 3, and 5 above. New TREECS™ modules are being developed to address various BMP assessments. The formulation, testing, and TREECS™ implementation strategies of these new modules are also presented in this report. Chapter 3 presents the development and testing of a new module to address BMP category 2, source removal. Chapters 4 and 5 present the development and testing of a generic reactor model and a sedimentation basin model, respectively, to address subsets of category 4 (AOI exit treatment). Chapter 6 discusses the implementation of new modules within TREECS™ and the joint use of the reactor and sedimentation basin BMPs. It is emphasized that other BMPs that are not discussed in this report may also be added to TREECS™ later as new treatment technologies are considered.

## 2 BMP Assessments with the Original Form of TREECS™

### Background

As noted in Chapter 1, the five general categories for range BMPs are:

1. Source loading management: reduce loadings to the area of interest (AOI)
2. Source removal: remove MC mass from the AOI
3. Source treatment: treat MC mass within the AOI to reduce export from the AOI
4. AOI exit treatment: treat AOI MC export fluxes as they exit the AOI
5. Down-gradient receiving water treatment: treat MC export fluxes within down-gradient receiving waters

TREECS™ in its original form (prior to adding BMP modules) can be used to address BMP categories 1, 3, and 5. The appropriate application of TREECS™ to address BMPs within each of these categories is discussed in the following sections. Phytotransformation, which falls into BMP category 3, does require some minor modifications to TREECS™ as described in the section below titled “Source treatment.”

### Source loading management

There are basically only three ways to control the MC source loading rate (i.e., mass of MC deposited in the AOI within a given time period). These include altering the following: the number of items fired in a given period of time (e.g., a year) for each munitions item; the types of munitions items fired; and the timing of AOI use. The number and types of items fired directly affect the amount of MC mass delivered to the AOI. The timing of AOI use pertains to when and for how long an AOI is in use. As an example, an AOI may be in use for five-year periods with a five-year break between the use periods. The duration of range use directly affects MC mass build-up within the AOI, thus affecting off-range exposure. Cycling of range use over a longer time period reduces MC buildup compared with continuous range use for a shorter time period.

Each of these three loading controls can be easily set within the *Site Conditions/Operational Inputs* screen of TREECS™. Within this screen,

the user specifies the types and numbers of munitions items fired, and these inputs can be varied from year to year.

## Source treatment

Source treatment within the AOI can be modeled by modifying input parameters within the Tier 2 soil model user interface (UI). MC fate in AOI soil can be affected via input parameters for each MC of interest. Two of the most obvious input parameters that can reflect source treatments are the MC soil-water partition coefficient ( $K_d$ ) and the MC degradation half-life ( $T_{1/2}$ ). These two parameters are located on the *Fate/Transport Parameters* screen of the Tier 2 soil model UI. Soil amendments can be used to increase  $K_d$  and shorten  $T_{1/2}$ . There is no general guidance on input values for these two parameters since such values are dependent on many factors including the MC of interest, the amendments, and local soil conditions.

Soil amendments can also be used to decrease MC water solubility (Larson et al. 2007). The MC solubility input value can be changed on the *Chemical-Specific Properties* screen of the soil model UI. The solubility is dependent on the specific MC of interest, the chemical characteristics of the amendment, and the local soil conditions.

Phytoremediation includes phytoextraction, phytostabilization, and phytotransformation. Phytoextraction is the uptake of MC by plants without significantly changing the MC chemical form and harvesting or removal of the plants, thus extracting the MC from the AOI. Plants can uptake metals, which do not transform. Thus, phytoextraction is a form of source removal, which is discussed in the next chapter. Phytostabilization is the use of plants to stabilize the soil to reduce erosion. This type of BMP can be addressed with TREECS™ in its original form by using a different type of land cover and condition to estimate a revised soil erosion rate. Phytotransformation is the uptake of MC by plants and transformation of the MC to a different, less harmful chemical. Phytotransformation is considered a source treatment BMP.

Phytotransformation as a source treatment can be modeled with the Tier 2 soil model by adjusting the MC half-life in soil ( $T_{1/2}$ ). There are inputs for two soil half lives; one is for dissolved MC in soil pore water, and the other is for soil-adsorbed MC. Adjusting the dissolved MC half-life for phytotransformation is probably the more reasonable approach. The half-life for

phytotransformation can be estimated using the method explained below. The half-life is computed from the first-order degradation rate  $\lambda$  ( $\text{yr}^{-1}$ ),

$$T_{1/2} = \frac{0.693}{\lambda} \quad (1)$$

The degradation rate can be estimated from

$$\lambda = \frac{G \text{ BCR } f_T}{Z_b \rho_b} \quad (2)$$

where

$G$  = plant production rate, kilograms dry plant mass/square meter-year

$BCR$  = bioconcentration ratio, milligrams MC in plant/kilograms plant / milligrams MC in soil/kilograms soil (dimensionless), where all mass is dry mass

$f_T$  = fraction of plant uptake (bioaccumulation) of MC that is transformed

$Z_b$  = soil active layer thickness, meters (default is 0.4 m)

$\rho_b$  = soil dry bulk density, kilograms/cubic meter

Estimates of  $G$ ,  $BCR$ , and  $f_T$  are required. The production rate depends on the plant species and the local growing conditions. Production rate values for various plant species are available in the literature. The  $BCR$  and  $f_T$  depend on the species of plant and the MC of interest. The soil bulk density can be estimated from soil class (e.g., silty loam, etc.), with a typical value of about 1,400  $\text{kg}/\text{m}^3$ . Methods are available for estimating  $BCR$  based on the octanol – water partitioning coefficient  $K_{ow}$  (McKone and Maddalena 2007). The average  $BCR$  of the HE RDX for a wide variety of plants is about 1.0 (McKone and Maddalena 2007). Once  $\lambda$  is estimated from Equation 2, the half-life for dissolved MC can be computed with Equation 1, and this half-life value is input for the dissolved MC half-life within the *Fate/Transport Parameters* screen of the Tier 2 soil model UI. The soil model can then be run as usual while taking into account the phytoremediation of the MC.

Phytotransformation is being implemented as an option in the Tier 2 model UI where the phytodegradation rate is automatically computed once the user has entered the required parameters ( $G$ ,  $BCR$ , and  $f_T$ ). The user is allowed to include both a natural degradation and phytodegradation. The

user enters the natural half-life in the original soil model UI input field located on the *Fate/Transport Parameters* screen. The model UI converts this half-life to a degradation rate (via Equation 1). The UI allows the user to select the option to include phytotransformation. If this option is selected, then an input dialog within the UI prompts for the phytodegradation inputs and computes the associated degradation rate. The natural degradation rate is added to the phytodegradation rate within the UI and is then provided to the model. This new feature requires modification to the soil model UI as described in Chapter 6, but it does not require modification of the soil model.

It must be recognized that the present method for estimating evapotranspiration (ET) within TREECS™ does not take into account land cover extent and type. Phytoremediation may result in ET values that are different from those estimated, and ET affects the overall soil hydrology. It may be necessary to implement an ET model that takes land cover into account.

### **Down-gradient receiving water treatment**

Down-gradient receiving surface waters can include ponds, lakes, streams, wetlands, and potentially bays of estuaries. Down-gradient receiving waters can also include groundwater. There are methods that can potentially remove MC from surface waters; a wide variety of groundwater remediation technologies have been used.

There are models within TREECS™ for simulating MC fate for surface water and groundwater. Although these models were not developed specifically for assessing remediation, it is possible to use them for evaluating remediation alternatives by adjusting the appropriate model inputs. For example, each of these models requires user inputs for MC fate parameters, including partition coefficients and half lives or degradation rates. In many cases, use of the standard Tier 2 modeling approach will be sufficient for simulating alternatives. However, for more complicated systems, features of the Advanced Tier 2 modeling approach will be required. Advanced Tier 2 provides flexibility for configuring more complex water systems, such as a down-gradient wetland with its effluent entering a stream, or an aquifer treatment zone that flows into a water supply aquifer.

Additional details on the use of Tier 2 or Advanced Tier 2 for modeling down-gradient receiving water treatment are not presented here since there are so many variations that need to be considered. Such applications will depend on the details of the water system involved and the remediation methods under consideration.

### 3 Source Removal

#### Background

Source removal can presently involve four methods: removal of soil containing MC; burning of the landscape; phytoextraction where plants uptake MC and are harvested or removed from the AOI; and unexploded ordnance (UXO) removal. Soil removal includes processing soils from impact berms of small arms firing ranges to extract metals. UXO removal includes selective removal of duds and metal and HE chunks that are exposed. All four of these removal methods can be addressed with modifications to the existing TREECS™ Tier 2 soil model as explained below. The removal of UXO duds does not require any modification to TREECS™ and can be addressed within the *Site Conditions/Operational Inputs* screen. The modifications required to implement source removal are described in the following four sections.

#### Model modifications for soil removal

The Tier 2 soil model requires modifications to account for MC source (or inventory) removal from the AOI that is accomplished by removing AOI soil, which can contain both solid phase MC and non-solid phase MC following solid phase dissolution in water. The solid phase MC mass balance equation with source removal is

$$\frac{dM_s}{dt} = L(t) - F_{dis} - F_{es} + F_{precip} - R_s M_s \quad (3)$$

where  $M_s$  is the solid phase MC mass (grams),  $t$  is time (years),  $L(t)$  is time-varying solid phase MC mass loading (grams/year),  $F_{dis}$  is MC dissolution flux (grams/year),  $F_{es}$  is the erosion flux of solid phase MC particles (grams/year),  $F_{precip}$  is the precipitation flux (grams/year) of MC due to dissolved pore water concentration exceeding the water solubility limit, and  $R_s$  is the MC source removal rate (years<sup>-1</sup>). The last term is the only term that is different in Equation 3 from the original version of the Tier 2 soil model as described by Dortch et al. (2011). It is noted that  $M_s$  is the mass of MC prior to dissolution into water where it can partition among water, soil, and air within the soil matrix.

The source removal rate  $R_s$  is related to the soil removal rate,

$$R_s(\text{soil removal}) = \frac{S_r}{\rho_b AZ_b} \quad (4)$$

where  $S_r$  is the soil removal rate (metric tons/yr),  $\rho_b$  is the soil dry bulk density (g/cm<sup>3</sup>), and the product  $AZ_b$  is the AOI total soil volume (m<sup>3</sup>) including water and air spaces. A factor of 1.0E6, which is the conversion from metric tons to grams, is cancelled by the factor 1.0E6, which is required to convert soil bulk density in grams per cubic centimeter to units of grams per cubic meter.  $A$  is the AOI surface area (square meters), and  $Z_b$  is the AOI active (contaminated) soil layer thickness (meters) as defined previously. The soil removal rate  $S_r$  is a model input that can vary from year to year. The constraint placed on the computed value of  $R_s$  is that it cannot be greater than 1.0. Values greater than 1.0 are not allowed, since this would result in more soil being removed in a year than is available within the AOI active soil layer. Thus,  $R_s$  can be thought of as the fraction of the AOI soil that is removed each year.

The mass of non-solid MC (following dissolution) must also be reduced to account for source removal since this mass can be dissolved in soil pore-water, adsorbed to soil, and exist as a vapor in air within soil air spaces. The mass balance for non-solid phase MC mass, including source removal, is stated as

$$\frac{dC_{tt}}{dt} = \frac{F_{dis}}{AZ_b} - \left[ \frac{d_e}{Z_b} (1 - e^{-\kappa}) N + \frac{E}{Z_b} + \frac{q_w}{\theta_w Z_b} F_{dp} + \right. \\ \left. (\lambda_l F_{dp} + \lambda_a F_{pp}) + \frac{K_v}{Z_b} F_{ap} + R_{ns} \right] C_{tt} - \frac{F_{precip}}{AZ_b} \quad (5)$$

where  $C_{tt}$  is the total concentration of non-solid phase MC on a total volume basis (grams per cubic meter), and  $R_{ns}$  is the non-solid phase MC removal rate (per year) and is equal to  $R_s$  for soil removal with the same constraint of not allowing values greater than 1.0. All other terms in the above equation are defined by Dortch et al. (2011) and are not repeated here for brevity. The only change to Equation 5 from the original model (Dortch et al. 2011) is the addition of the last term within the bracket,  $R_{ns}$ , to account for source removal.

## Model modifications for burning

It is possible to remove reactive MC, such as explosives and propellants, through combustion by burning the landscape. It is not known whether or not non-solid phase MC is removed during burning. To be conservative, it is assumed that only solid phase MC is removed by burning. Thus, Equation 3 is invoked, but a different equation is required for computing  $R_s$  due to burning,

$$R_s(\text{burning}) = 4,047 \frac{B_R}{A} \quad (6)$$

where  $B_R$  is the burn rate (acres/year), and the factor 4,047 is the conversion from acres to square meters. The value of  $R_{ns}$  is set to zero in Equation 5 for burning. Computed values of  $R_s$  for burning are constrained the same way as those for soil removal are constrained, i.e., values greater than 1.0 are not allowed, since this would result in an area being burned in one year that is larger than the area available within the AOI. Thus,  $R_s$  in this case is equivalent to the fraction of the AOI landscape that is burned each year.

Most inorganic MC, such as metals, will not be removed by burning. The user will be required to select which of the modeled MC are allowed to be removed by burning.

## Model modifications for phytoextraction

It is assumed that only dissolved MC can be taken up by plants. Therefore, the value of  $R_s$  is set to zero in Equation 3. The value of  $R_{ns}$  for use in Equation 5 is computed using a variation of Equation 2 as follows to account for phytoextraction

$$R_{ns}(\text{phytoextraction}) = \frac{F_{dp} f_H G BCR}{Z_b \rho_b} \quad (7)$$

where  $F_{dp}$  is the dimensionless factor to account for the soil pore-water-dissolved portion of the total non-solid phase MC concentration in soil, and  $f_H$  is the fraction of the plant production rate that is harvested. All other terms have been previously defined. The formulation for computing  $F_{dp}$  is provided by Dortch et al. (2011).



The fraction of production harvested each year,  $f_H$ , is the same as the ratio  $A_H/A$ , where  $A_H$  is the surface area of the AOI that is harvested. This ratio cannot be greater than 1.0, and it is equivalent to the fraction of the AOI that is treated with phytoextraction each year. This is the only constraint placed on the values of  $R_{ns}$  computed with Equation 7.

It is possible that burning could be the method of harvesting if burning the plants destroys the MC. Burning for phytoextraction is assumed to be independent of burning the landscape for source removal as described in the previous section. The method of harvesting or plant extraction is not a model feature. Similar to burning, phytoextraction does not apply for all types of MC. Thus, the user will be required to select which MCs are applicable to phytoextraction.

As mentioned in the previous chapter, vegetation production can result in ET values that are different from the estimated values since the present ET method within TREECS™ does not take land cover into account. A method for estimating ET that takes land cover into account could be implemented in the future.

## UXO removal

As stated previously, UXO removal includes selective removal of duds as well as chunks of exposed metals and HE. Duds are munitions that do not encounter any explosion. Duds are sometimes removed from ranges by range clearance personnel. Although UXO removal is performed primarily to remove intact duds, exposed chunks of HE from low-order detonations can also be removed. The extraction of metals from small arms impact berms via soil processing should be addressed as soil removal. Selective removal of metal chunks from impact areas can also occur. Metal chunks are typically associated with spotting projectiles that do not explode, such as those containing depleted uranium (DU) that were used in the Davy Crockett training round. Thus, TREECS™ allows UXO removal associated with duds and chunks of exposed HE and metals.

Presently duds only contribute to MC residue loading if percentages for sympathetic duds and their yield are set greater than zero in the *Operational Inputs* screen on the *Site Conditions* tab. Thus, TREECS™ presently does not handle corrosion and perforation of duds that can expose HE. Sympathetic duds occur when a round explodes close enough to a dud to cause it to explode or to cause the dud casing to open, exposing HE.

Although the default values are zero, the user can enter the percentages for sympathetic duds and their yield. If the percentage of sympathetic duds remains zero, this can mean that either all of the duds are removed or none of them exploded due to another round exploding. Therefore, HE source removal associated with UXO dud clearance does not require any modifications to TREECS™. The user can simply set the percentage of sympathetic duds to zero, which has the same effect as removing all duds.

Selective removal of exposed HE and metal chunks can be addressed by modification of the Tier 2 soil model and its UI as follows. An additional term must be subtracted from the right-hand side of Equation 3 to account for selective removal of solid phase MC mass. This selective removal term (*SR*, grams/year) is the amount of solid phase MC mass that is removed from the AOI each year for each MC. To define this loss term, an additional input column for *Selective Removal Rate* (grams/year) must be added next to the *Mass Residue Loading* column on the Tier 2 soil model UI *Site Characteristics* input screen. The default values in this column are zero for each MC and each year. The user will be able to change the values from zero to positive values indicating annual removal of MC. These values can be varied by the user from year to year. The addition of the *SR* term to the Tier 2 soil model also requires adding a check within the soil model to ensure that the value for AOI solid phase MC mass  $M_s$  remains at or above zero at all times. Inclusion of the selective removal term provides an additional, generic means for reducing solid phase MC mass from the AOI each year.

## TREECS™ implementation

Source removal is being implemented as an option in the Tier 2 soil model UI. If source removal is chosen, then the user must provide inputs for each type, i.e., soil removal, burning, and phytoextraction. UXO removal is treated differently, as described in the previous section. It is possible to include any and all of these three types (i.e., soil removal, burning, and phytoextraction). However, these three types of source removal are assumed to be mutually exclusive. This means that an area treated with one method cannot be treated with another method at any time. Thus, for example, soil removal cannot be used for burning or phytoextraction at any time. This exclusivity requires a check. As explained previously, the soil removal rate, the burning removal rate, and the harvesting fraction translate into fractions of the AOI treated in each year. As explained below, these three inputs can vary from year to year. However, for the treated areas

to be mutually exclusive for all years, it is necessary to maintain the following constraint:

$$\max[R_s(\text{soil removal})_i] + \max[R_s(\text{burning})_i] + \max[(f_H)_i] \leq 1.0 \quad (8)$$

where the subscript  $i$  denotes the input year. Selective removal can be included with any of the other three source removal methods without any constraints.

If the source removal option is used, the UI queries the user to input the time series of soil removal rates (metric tons/year), burning rates (acres/year), and plant harvesting fractions. These time series are input as a table of time in years with input values for the three removal types for each update year. The table also shows the computed values of  $R_s(\text{soil removal})$  and  $R_s(\text{burning})$  so that the user can easily see all fractions in Equation 8. If removal types are inactive for any given year, then input values for the excluded removal type are set to zero for that year. This provides the flexibility to change any of the removal types from year to year. At least two time points (years) are required for these inputs, and rates are held constant for each update until the simulation time has reached the next update year.

The UI verifies that the constraint of Equation 8 is not violated. If violation occurs, the user is warned and must change values in the input table until the constraint is satisfied. The UI also queries the user to input  $G$  and  $BCR$  if any of the phytoextraction harvest fractions are greater than zero. Only constant values of these two inputs are allowed. Once the input table has been entered and the constraint satisfied, the appropriate equations for computing  $R_s$  and  $R_{ns}$  for each removal type are executed within the soil model UI based on the inputs for each removal type. The computed  $R_s$  and  $R_{ns}$  values for each type are then added together for use in Equations 3 and 5.

## 4 Reactor Model for MC Degradation

### Background

A generic one-dimensional reactor model is required for estimating the removal of MC that is passed through a degradation reactor while exiting the AOI. The purpose of this model is to predict the degradation and resulting exit concentrations of MC that are passed through the reactor. Various MC being treated with this reactor are envisioned to be those that have relatively low sediment–water partitioning distribution coefficients ( $K_d$ ), such as most explosives and propellants. The fraction of total MC concentration in water that is dissolved depends on the total suspended solids (TSS) concentration and  $K_d$  as shown in Table 1. From examination of this table, it can be concluded that most of the MC concentration in water is dissolved for  $K_d$  less than 100 kg/L for a wide range of TSS concentrations. For MC that partition more strongly with TSS, a reactor of this type may not be a suitable treatment option due to the necessity to trap TSS, thus causing clogging. A sedimentation basin would be a better treatment alternative. Thus, this model assumes that the MC entering the reactor is dissolved, and particulate MC is passed unaltered. The formulation of this model is described below.

Table 1. Fraction of MC dissolved in water as related to TSS and  $K_d$ .

| TSS, mg/L | $K_d$ , L/kg | Fraction dissolved |
|-----------|--------------|--------------------|
| 100       | 1            | 1.000              |
| 1000      | 1            | 0.999              |
| 10,000    | 1            | 0.990              |
| 100       | 10           | 0.999              |
| 1000      | 10           | 0.990              |
| 10,000    | 10           | 0.909              |
| 100       | 100          | 0.990              |
| 1000      | 100          | 0.909              |
| 10,000    | 100          | 0.500              |

## Model formulation

This model accounts for MC removal along the flow axis of the reactor. The reactor could be oriented horizontally or vertically to treat AOI runoff or infiltration, respectively. The reactor is assumed to be a water-saturated, porous medium with uniform dimensions perpendicular to the flow axis (i.e., width,  $W_r$  (meters), and depth,  $H_r$  (meters), for horizontal flow) and uniform media properties, such as reactor porosity,  $\phi_r$ . MC concentration is assumed to be uniform except along the flow axis.

Water containing MC flows directly and unaltered from the AOI into the up-gradient end of the reactor. For a given water inflow rate  $Q$  (cubic meters/day), the Darcy transit speed  $U$  (meters/day) through the reactor can be computed from  $U = Q/(W_r H_r)$ . The model takes into account sorption onto the solid media and degradation.

From Zheng and Wang (1999), the time-varying, one-dimensional reactive transport equation is

$$R \frac{\partial C}{\partial t} + v \frac{\partial C}{\partial x} = D_x \frac{\partial^2 C}{\partial x^2} - \lambda_d C - \lambda_p \frac{\rho_{br} K_{dr}}{\phi_r} C \quad (9)$$

where

$C$  = MC concentration in the reactor pore water (milligrams/liter)

$t$  = time (days)

$x$  = distance along the flow axis of the reactor (meters)

$\phi_r$  = porosity of the reactor media, void or water volume/total volume

$D_x$  = dispersion coefficient in the reactor flow (square meters/day)

$R$  = reactor retardation factor (dimensionless)

$v$  = pore-water velocity of the reactor flow,  $v = U/\phi_r$  (meters/day)

$\rho_{br}$  = dry bulk density of the reactor media (kilograms/liter)

$K_{dr}$  = distribution coefficient for sorption partitioning in the reactor (liters/kilogram)

$\lambda_d$  = degradation rate for dissolved MC (day<sup>-1</sup>)

$\lambda_p$  = degradation rate for MC adsorbed to reactor material (day<sup>-1</sup>)

Equation 9 assumes equilibrium partitioning and first-order reaction kinetics. With linear partitioning, the reactor retardation factor is then expressed as

$$R = 1 + \frac{\rho_{br} K_{dr}}{\phi_r} \quad (10)$$

Neglecting dispersion and assuming that the degradation rates for dissolved and adsorbed MC are the same within the reactor ( $\lambda_d = \lambda_p = \lambda_r$ ), Equation 9 can be written as

$$\frac{\partial C}{\partial t} + \frac{v}{R} \frac{\partial C}{\partial x} = -\lambda_r C \quad (11)$$

Assuming conditions are at steady state, Equation 11 reduces to the following analytical solution for  $x = L_r$ , which is the total length of the reactor along the flow axis:

$$C_L = C_i \exp\left(-\frac{\lambda_r R L_r}{v}\right) \quad (12)$$

where  $C_i$  and  $C_L$  are the dissolved MC concentrations in water entering and exiting the reactor, respectively. This rather simple analytical solution can be applied over time with time-varying updates for flow rate and entering MC concentration or load, but the output concentration is assumed to be at steady state with respect to each input update, which means that steady state is reached rather quickly relative to the loading updates. This is expected to be the case for most of the time, especially if annual loadings are used.

## Example solutions

The analytical model (Equation 12) was applied for the following conditions:

- $Q = 1000 \text{ m}^3/\text{day}$
- $W_r = 3 \text{ m}$
- $H_r = 1 \text{ m}$
- $L_r = 10 \text{ m}$
- $\phi_r = 0.5$
- $U = 333.3 \text{ m/day}$ , which is computed
- $v = 666.7 \text{ m/day}$ , which is computed

- $\rho_{br} = 1.4 \text{ kg/L}$

The degradation rate  $\lambda_r$  and distribution coefficient  $K_{dr}$  were varied during the solution, resulting in the results plotted in Figure 1. This figure shows how increasing  $K_{dr}$  results in greater MC removal for the same degradation rate.

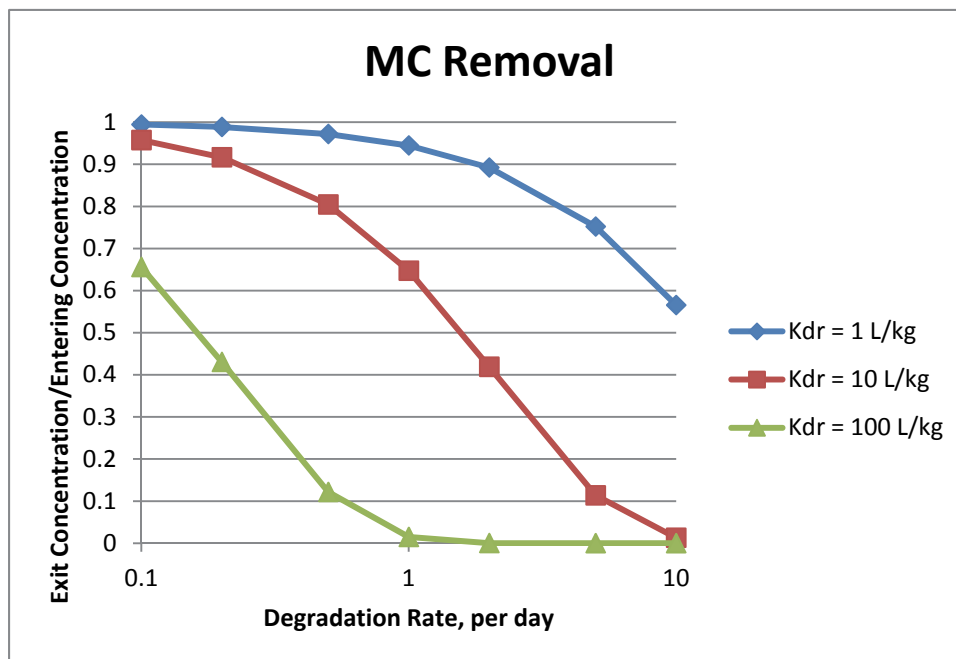

Figure 1. Dimensionless MC exit concentration as affected by degradation rate and  $K_{dr}$ .

## Inputs and outputs

The above reactor model is implemented within TREECS™ as an additional module. There are potentially two types of reactor treatments of MC fluxes leaving the AOI: 1) overland fluxes to surface water, including the option for soil interflow that has re-entered surface flow; and 2) leaching fluxes to the vadose zone. The user has the option of including either type of reactor or both. The input parameters for each type are the same, but the input values can be different.

The Tier 2 soil model generates five output fluxes to comprise AOI MC mass export (mass/time) to down-gradient models: runoff flux ( $F_r$ ), which is all dissolved; soil erosion flux ( $F_e$ ), which includes dissolved and particulate (soil adsorbed); soil interflow flux ( $F_i$ ), which is dissolved; leaching flux ( $F_l$ ), which is dissolved; and the flux due to erosion of solid phase MC ( $F_{es}$ ), which is particulate since it has not yet dissolved. Soil

erosion flux contains soil-adsorbed MC and MC dissolved in pore water. Without BMPs, the five fluxes are used by the soil model UI to create two types of output within the water flux file (WFF) used by down-gradient models, one for surface water and one for the vadose zone/groundwater. Both WFF output types contain MC mass fluxes (grams/year) and water flows (cubic meters/year). The WFF surface water also contains two data types for MC mass fluxes, dissolved and particulate (i.e., adsorbed to soil), whereas all of the WFF vadose MC mass fluxes are assumed to be dissolved. The WFF water flow to vadose zone consists of net infiltration after accounting for losses to ET and soil interflow. The WFF water flow to surface water is the combination of runoff and soil interflow, which resurfaces to surface flow.

The soil model UI combines  $F_r$  and  $F_i$  to form the combined dissolved flux within the WFF surface water whenever no BMPs are being used. When BMPs are implemented, users have the option, as shown in Figure 2, of including or not including soil interflow flux within the treated influent. If interflow flux is included in the treatment, then all of the soil interflow flux and flow values are combined with the overland flux and flow values. Interflow cannot be proportioned; thus, either all or none of the interflow is combined with overland flow.

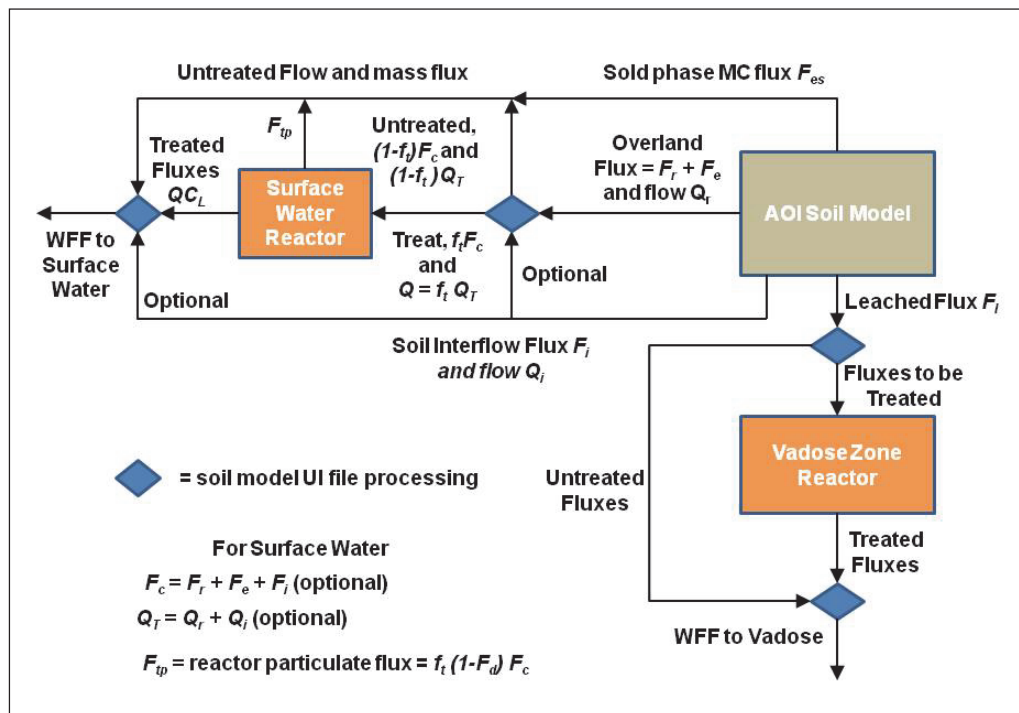

Figure 2. Schematic of reactor types and their interactions with input and output files associated with the soil model UI.



The particulate flux of the WFF for surface water contains all of the erosion flux, whereas a portion of  $F_e$  is actually dissolved. This misrepresentation presents no adverse consequences so long as the total MC flux value (particulate and dissolved) is used to compute reactor influent partitioning and concentrations, which is the case in the example shown below. Partitioning of influent is necessary since the distribution coefficient for surface water can be quite different from the one used for soil.

The original Tier 2 soil model is based on average annual hydrology. Another version of the soil model that is currently being developed and implemented uses daily hydrology. For these reasons, mass and water volume fluxes can involve daily or annual units, i.e., grams/day or grams/year and cubic meters/day or cubic meters/year. Also, it is possible that not all of the fluxes/flows exiting the AOI will be treated. Some fluxes/flows may bypass the treatment reactor. Thus, the user is required to enter the fraction of total flow from AOI to surface water or vadose zone that is being treated,  $f_i$ .

When a BMP includes a reactor for surface water, the soil model UI adds the  $F_r$  and  $F_e$  fluxes to obtain the combined non-solid phase MC overland flux for surface water. The eroded solid phase MC overland flux  $F_{es}$  is not included but retained as a separate untreated flux as shown in Figure 2. It is assumed that the solid phase flux will not dissolve or settle as it passes through the reactor. If the user chooses to include soil interflow for reactor surface water treatment as shown as an option in Figure 2, then  $F_i$  is added to the overland flux resulting in a combined, total flux  $F_c$  (either grams/day or grams/year) for the update interval.  $F_c$  is simply the leaching flux  $F_l$  for a vadose zone reactor.

The total (dissolved and particulate) influent concentration  $C_{Ti}$  (g/m<sup>3</sup>) is computed from the total flux as follows,

$$C_{Ti} = \frac{F_c}{Q_T} \quad (13)$$

where  $Q_T$  is the total water flow rate from AOI to either surface water (including soil interflow if this option is selected) or to the vadose zone (either cubic meters/day or cubic meters/year) due to either overland runoff and interflow (if selected) or leaching, respectively. Thus, for surface water flow that includes soil interflow,  $Q_T = Q_r + Q_i$ , where  $Q_r$  is the

overland runoff flow rate, and  $Q_i$  is the soil interflow flow rate. For leaching,  $Q_T$  is simply the leaching flow rate. The reactor flow is  $Q = f_i Q_T$ . The untreated flow equals  $(1 - f_i) Q_T$ .

The dissolved influent concentration  $C_i$  for surface water is determined from  $C_i = F_d C_{Ti}$ , where the fraction dissolved  $F_d$  is computed from

$$F_d = \frac{1}{1 + 1.0E^{-6} TSS_i K_{dw}} \quad (14)$$

where  $TSS_i$  is the total suspended solids concentration (milligrams/liter) of the influent, and  $K_{dw}$  is the water – TSS partitioning distribution coefficient for the MC, which can be different from  $K_d$  used for soil pore water or the partitioning used for the reactor,  $K_{dr}$ . All of the leaching flux is dissolved, or  $F_d = 1.0$ . The factor  $10^{-6}$  in Equation 14 is the conversion from milligrams to kilograms that is required to convert  $TSS$  in milligrams/liter to kilograms/liter. The concentration of the influent TSS is computed from

$$TSS_i = \frac{1.0E^6 \rho_b A E}{Q_T} \quad (15)$$

where  $E$  is the AOI soil erosion rate (either meters/day or meters/year);  $Q_T$  is the AOI daily water flow rate from AOI to the surface water (either cubic meters/day or cubic meters/year) as explained previously; as before,  $A$  is the AOI surface area (square meters); and  $\rho_b$  is AOI soil dry bulk density as before in units of kilograms/liter. The factor  $1.0E6$  is the conversion from kilograms/liter to grams/cubic meter or milligrams/liter.

Since the reactor only removes dissolved MC, the portion of reactor influent flux that is in particulate form ( $F_{tp}$ ) must be added back to the untreated fluxes. The reactor particulate flux is computed from  $F_{tp} = f_i (1 - F_d) F_c$ .

Input parameters for the reactor model include the following:  $L_r$ ,  $W_r$ ,  $H_r$ ,  $\phi_r$ ,  $\rho_{br}$ ,  $K_{dr}$ ,  $\lambda_r$ ,  $f_t$ , and  $K_{dw}$ . Additionally, the user must declare whether soil interflow is treated or untreated. With these parameters and the soil model input and output, all information for running the reactor model is available. The reactor water flow rate,  $Q$ , is computed from  $Q = f_i Q_T$ . After

solving the reactor output concentration, the reactor effluent mass flux is the product  $QC_L$ , all of which is dissolved.

Figure 2 shows a schematic of the reactor model options with the associated processing. As explained previously, it is possible that the reactor will not capture all of the water fluxes from the AOI. The UI allows for such cases by requiring input for  $f_t$ . The reactor output fluxes are added to the untreated AOI export fluxes, and the combined results are written to the WFF file used by down-gradient modules. It is noted that the two data types for surface water (dissolved and particulate) are maintained in the WFF; thus, untreated soil model fluxes as output by the soil model must be maintained. The Tier 2 soil model UI allows the option of surface water or vadose zone reactors, or both.

## 5 Sedimentation Basin Model for MC Removal

### Background

A generic sedimentation basin model is required to estimate the removal of MC via settling that is diverted to the basin upon exiting the AOI as overland flow. The purpose of this model is to predict the trapping and resulting exit concentrations of MC that are passed to the sedimentation basin. MC with relatively high suspended sediment – water partitioning distribution coefficients ( $K_{dw}$ ), such as most metals, would be most appropriate for this type of treatment. The formulation of this model is described below.

### Model formulation

The simplifying assumption is made for the model that the sedimentation basin is fully mixed, i.e., a batch reactor. The only removal process is settling of particulate MC. The mass balance of MC within the sedimentation basin is stated as follows,

$$V_b \frac{dC_T}{dt} = QC_{Ti} - QC_T - v_s A_b F_p C_T \quad (16)$$

where

- $C_T$  = MC total (dissolved and particulate) concentration in water within and exiting the basin (mg/L)
- $C_{Ti}$  = MC total (dissolved and particulate) concentration in water entering the basin (mg/L)
- $t$  = time (days)
- $F_p$  = fraction of total MC concentration in water that is particulate
- $Q$  = water flow rate into and exiting the basin (m<sup>3</sup>/day), consisting of runoff and potentially soil interflow
- $A_b$  = water surface area of the basin, or volume/depth (m<sup>2</sup>)
- $V_b$  = water volume of the basin (m<sup>3</sup>)
- $v_s$  = settling rate of suspended solids (m/day)

Assuming steadystate, the solution to Equation 16 is

$$C_T = \frac{C_{Ti}}{1 + \frac{v_s A_b F_p}{Q}} \quad (17)$$

The water flow rate  $Q$  through the basin is determined in the same way as it is for the reactor, i.e.,  $Q = f_t Q_T$ , where all variables were defined in the previous chapter. As before,  $Q_T$  includes the overland runoff flow  $Q_r$  and the soil interflow  $Q_i$ , if that option is selected. The ratio  $A_b/Q$  is the inverse of the hydraulic loading rate. The fraction of MC total concentration that is particulate  $F_p$  is computed from

$$F_p = \frac{10^{-6} TSS K_{dw}}{1 + 10^{-6} TSS K_{dw}} \quad (18)$$

where all terms were defined in the previous chapter, and also  $F_p = 1 - F_d$ . A suspended solids mass balance must be conducted for the sedimentation basin, where  $TSS$  in Equation 18 is the total suspended solids concentration within the basin and is computed from an analogous form of Equation 17,

$$TSS = \frac{TSS_i}{1 + \frac{v_s A_b}{Q}} \quad (19)$$

$TSS_i$  is the basin influent TSS concentration (milligrams/liter) and is computed from Equation 15 as explained in the previous chapter.

The total concentration of MC entering the sedimentation basin,  $C_{Ti}$ , is calculated as explained in the previous chapter by dividing the total mass flux from the AOI to surface water ( $F_c$ ) by the total water flow rate from AOI to surface water  $Q_T$ . If the option to include soil interflow is selected, then  $F_c$  is the sum of the overland flux and soil interflow flux, and  $Q_T$  is the sum of the runoff flow rate and the soil interflow flow rate. As stated previously,  $Q = f_t Q_T$ .

## Example solutions

Example solutions are provided for lead that is exported from the AOI as dissolved and particulate MC. The input conditions for this example are

provided in Table 2 based on a previous application of TREECS™ for West Point (Dortch 2012) that used annual average hydrology and erosion. Soil interflow was not included in surface water flow in this example. The water runoff rate was multiplied by the AOI area and divided by 365 to obtain the daily runoff flow rate of 86.99 m<sup>3</sup>/day. The annual erosion rate was converted to a daily rate. Equation 15 was applied using values in Table 2 to obtain  $TSS_i = 4,979$  mg/L.

Table 2. Inputs for example application of the sedimentation basin model.

| Input                                | Units          | Value  |
|--------------------------------------|----------------|--------|
| AOI erosion rate                     | m/yr           | 0.0023 |
| AOI runoff rate                      | m/yr           | 0.656  |
| Basin water column $K_{dw}$ for lead | L/kg           | 4,000  |
| AOI surface area $A$                 | m <sup>2</sup> | 48,400 |
| $\rho_b$                             | kg/L           | 1.42   |

The settling rate was varied, as well as the hydraulic loading rate for the basin,  $Q/A_b$ , and Equation 17 was used to compute the ratio  $C_T/C_{Ti}$ , or the dimensionless total lead concentration in the basin. In order to solve Equation 17, the basin TSS concentration had to be computed first using Equation 19. The resulting TSS concentration was used to compute the lead particulate fraction  $F_p$  using Equation 18. This value of  $F_p$  was then used in Equation 17 to compute  $C_T/C_{Ti}$ .

The results of the above applications for the imposed input conditions are plotted in Figure 3 as removal efficiency ( $RE$ , %) versus hydraulic loading rate.  $RE$  is defined as

$$RE = 100 \left( 1 - \frac{C_T}{C_{Ti}} \right) \quad (20)$$

Thus,  $RE$  is a measure of trapping efficiency, where 100% is total removal or trapping of entering MC. Figure 3 reveals that trapping of lead within the basin decreases as the hydraulic loading rate increases, and the influence of the hydraulic loading rate diminishes with an increasing settling rate.

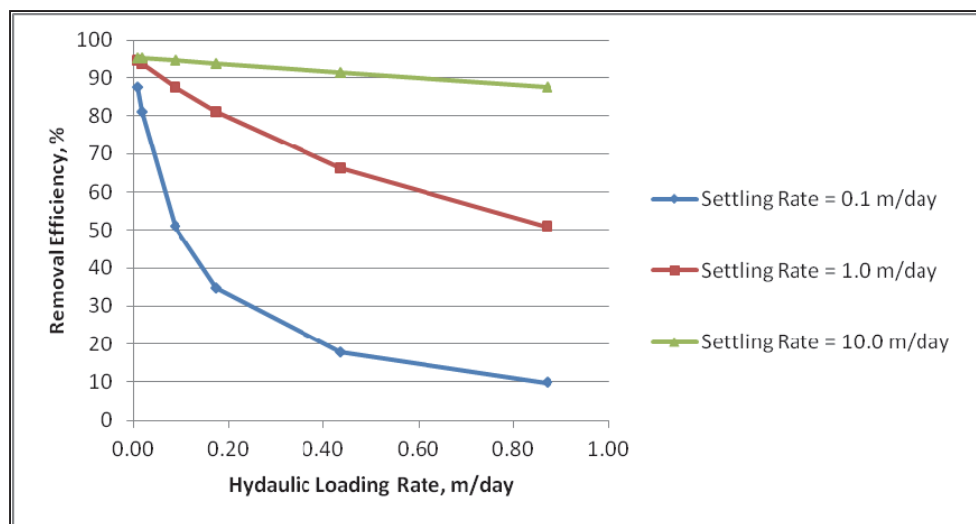

Figure 3. Removal efficiency of lead for sedimentation basin as related to hydraulic loading rate and TSS settling rate.

## Inputs and outputs

The sedimentation basin model is implemented within TREECS as an additional module that is called from the Tier 2 soil model UI. As described previously, the Tier 2 soil model produces two data types written within the WFF for surface water. These two data types are dissolved fluxes resulting from runoff and adsorbed (particulate) fluxes resulting from erosion. Just as for the reactor model, when there is a sedimentation basin down-gradient of the AOI, the Tier 2 soil model UI combines dissolved and particulate fluxes, and as shown in Figure 4, the total flux can be optionally combined with soil interflow fluxes, which are also dissolved. As in the previous chapter, either all or none of the soil interflow and flux is combined with overland flow and flux. Additionally, the combined overland flux in the case of a sedimentation basin includes the solid phase MC erosion flux  $F_{es}$ , if the solid phase erosion option is turned on in the soil model. The solid phase erosion flux is included so that solid phase MC that enters the basin can settle out. However, the sedimentation basin model does not distinguish between MC adsorbed to TSS and solid phase MC; rather, all surface water fluxes are combined to form  $F_c$  used to compute  $C_{Ti}$  from Equation 13. Thus, basin influent concentrations settle as adsorbed particulates rather than separate solid phase particles.

As with the reactor model of the previous chapter, it is possible that the sedimentation basin will not capture all of the surface water flux from the AOI. The UI allows for such cases by requiring an input for the fraction of AOI surface water export flux to be treated ( $f_t$ ) by the basin, the same as

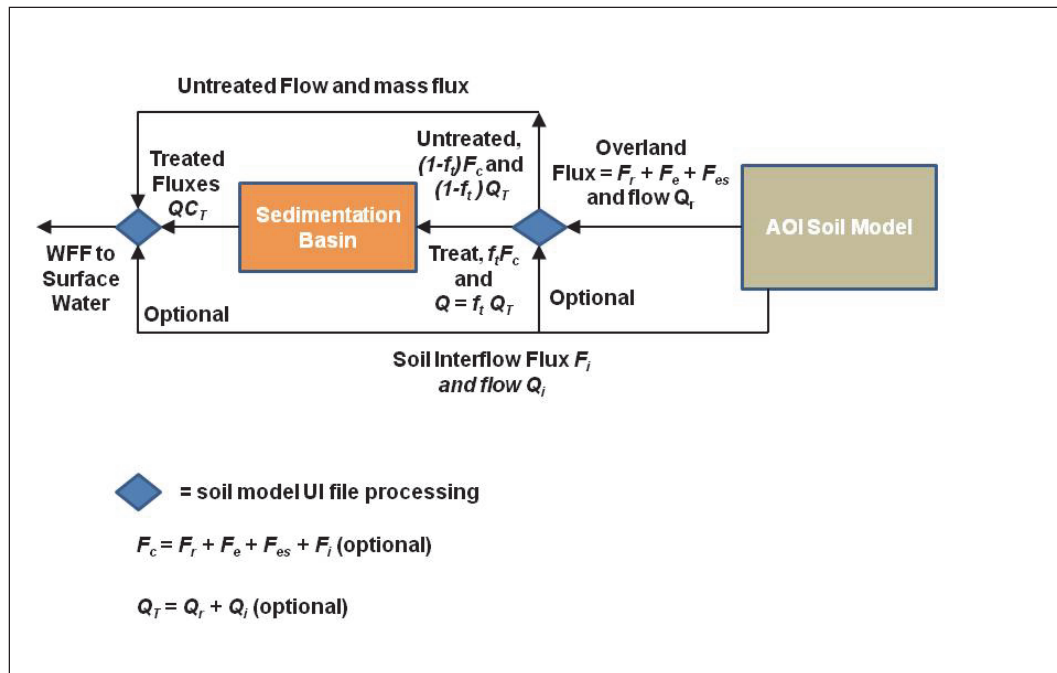

Figure 4. Schematic of sedimentation basin model interactions with input and output files associated with the soil model UI.

for the reactor model. As shown in Figure 4, the sedimentation basin output fluxes are then added to the untreated AOI surface water export fluxes, as well as the AOI soil interflow fluxes if untreated, and the combined results are written to the WFF used by down-gradient surface water models. It is emphasized that the two data types (dissolved and particulate) are maintained in the WFF; thus, the untreated individual fluxes output by the soil model must be tracked. The sedimentation basin total mass flux output is the product  $QC_T$ . However, this total flux output of the sedimentation basin must be partitioned into particulate and dissolved fluxes ( $F_{sbp}$  and  $F_{sbd}$ , respectively) to maintain the two data types within the WFF for surface water. This partitioning is computed as follows,

$$F_{sbp} = F_p C_T Q \quad (21)$$

$$F_{sbd} = (1 - F_p) C_T Q \quad (22)$$

where  $F_p$  is computed from Equation 18. There is no need to account separately for the term  $F_{tp}$  as is done for the reactor model.

Additional input parameters required by this model that have not already been entered for the Tier 2 soil model include:  $f_t$ ,  $v_s$ ,  $A_b$ , and  $K_{dw}$ . The user



must also choose whether or not soil interflow is included in the treatment. Water flow rate  $Q$  and entering total MC concentration  $C_{Ti}$  are boundary conditions that are obtained from the soil model output as explained previously.

The Tier 2 soil model UI provides the user with the option of sedimentation basin treatment. If a sedimentation basin is included, then the soil model UI provides a sedimentation basin input dialog to be completed by the user. The UI then executes the model equations and writes the associated WFF file for use by other down-gradient models.

## 6 Implementation of New Modules within TREECS™

### New input tabs for the soil model UI

Three new tabs are being added to the soil model UI after the Model Options tab. The three tabs are entitled: AOI Phytotransformation BMP; Source Removal BMPs; and AOI Export Treatment BMPs. Selection of each tab launches a new screen for specifying input parameters. The user can use all three tabs, which will include all three BMP types, within the same application (.trp file). Alternatively, there can be one new tab for BMPs, and the UI screen for this tab can include all of the above three options that would launch additional input screens.

Input features for the AOI phytotransformation screen are described in Chapter 2. Input features for the source removal screen are described in Chapter 3. Users can select from the following options for the AOI export treatment screen:

1. Degradation reactor for surface water
2. Degradation reactor for vadose zone
3. Degradation reactor for surface water and vadose zone
4. Sedimentation basin for surface water
5. Sedimentation basin for surface water and degradation reactor for surface water
6. Sedimentation basin for surface water and degradation reactors for surface water and vadose zone
7. Sedimentation basin for surface water and degradation reactor for vadose zone

Only one of the seven options can be selected for a given application (.trp file). The selected option determines the look and input requirements for other portions of the screen.

The input requirements for options 1, 2, and 3 above are identical except that they are used for different purposes, and option 3 has two sets of inputs rather than one set. Input requirement details for options 1–3 are

discussed in Chapter 4. Input requirement details for option 4 are discussed in Chapter 5.

Option 5 is the joint use of a sedimentation basin and degradation reactor in series for surface water treatment. The implementation and input requirements for this option are discussed below. Option 6 is a minor variation of option 5 in which a degradation reactor is also included for the vadose zone. Option 7 is simply the inputs for options 2 and 4 queried on the same screen.

### **Joint use of degradation reactor and sedimentation basin**

The two previous chapters address adding a degradation reactor or sedimentation basin to TREECS™ for treatment of water exiting the AOI. This section addresses the joint use of a sedimentation basin and a degradation reactor for surface water treatment. In this scenario, it is assumed that the surface water flow from the AOI first passes through the sedimentation basin to remove solids and particulate MC and then passes through the reactor to remove dissolved MC. A vadose reactor can also be used with this case.

Figure 5 is a schematic of the joint treatments showing the various inputs and outputs. The files and associated inputs and outputs are very similar to those shown in Figures 2 and 4 after combining treatment objects and recognizing that the output flux from the sedimentation basin is the input flux for the surface water reactor.

All computations for the sedimentation basin, including influent MC and TSS concentration, are identical to those presented in Chapter 5. However, there are some differences in the computations for the reactor. The reactor influent TSS concentration  $TSS_i$  is now equal to the computed sedimentation basin TSS. The MC total concentration of the reactor influent is now the sedimentation output concentration  $C_T$ . The reactor particulate flux that must be added back to the untreated fluxes is computed from  $F_{tp} = (1 - F_d)QC_T$ . The options to include or exclude soil interflow within treatment and to treat a fraction of the surface water fluxes are available only for the sedimentation basin. Thus, it is assumed that all soil interflow enters either before the sedimentation basin or after the reactor. No interflow can enter between the basin and reactor. Likewise, it is assumed that all flow that is treated with the basin is also treated with the reactor, or

that the two are in series with each other and no flow is added or lost between them. Cases that require the basin and reactor to be in parallel should probably be modeled with two separate AOIs, such as one for a small arms range where the MCs are metals and one for an impact area where the MCs are HE.

The input parameters for the joint use of the sedimentation basin and the reactor, beyond those needed for the Tier 2 soil model, consist of the following:  $f_t$ ,  $K_{dw}$ ,  $v_s$ ,  $A_b$ ,  $L_r$ ,  $W_r$ ,  $H_r$ ,  $\phi_r$ ,  $\rho_{br}$ ,  $K_{dr}$ , and  $\lambda_r$ . Additionally, the user must declare whether soil interflow is treated or untreated.

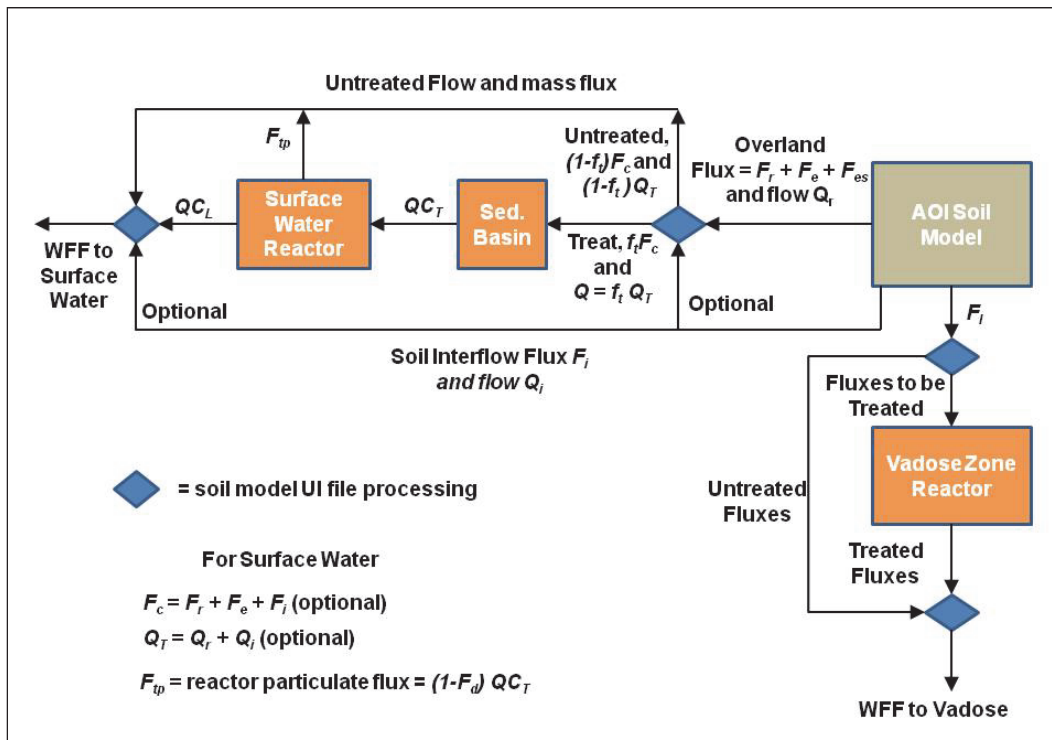

Figure 5. Sedimentation basin and reactor model interactions with input and output files associated with the soil model UI.

## References

- Dortch, M. S. 2012. *Validation applications of the Training Range Environmental Evaluation and Characterization System (TREECS™)*. Technical Report ERDC/EL TR-12-3. Vicksburg, MS: U.S. Army Engineer Research and Development Center.
- Dortch, M.S., B. E. Johnson, Z. Zhang, and J. A. Gerald. 2011. *Methods for Tier 2 modeling within the Training Range Environmental Evaluation and Characterization System*. Technical Report ERDC/EL TR-11-2. Vicksburg, MS: U.S. Army Engineer Research and Development Center.
- Gent, D. B., J. L. Johnson, D. R. Felt, G. O'Connor, E. Holland, S. May, and S. L. Larson. 2010. *Laboratory demonstration of abiotic technologies for removal of RDX from a process waste stream*. Technical Report ERDC TR-10-8. Vicksburg, MS: U.S. Army Engineer Research and Development Center.
- Jenkins, T., and C. Vogel. 2012 (draft). *Department of Defense best management practices for operational ranges*. Prepared for Department of Defense Environmental Security Technology Certification Program by Noblis.
- Larson, S. L., J. L. Davis, W. A. Martin, D. R. Felt, C. C. Nestler, G. Fabian, G. O'Connor, G. Zynda, and B. A. Johnson. 2008. *Grenade range management using lime for dual role of metals immobilization and explosives transformation*. Technical Report ERDC TR-08-24. Vicksburg, MS: U.S. Army Engineer Research and Development Center.
- Larson, S. L., P. G. Malone, C. A. Weiss, W. A. Martin, C. Trest, G. Fabian, M. F. Warminsky, D. Mackie, J.J. Tasca, J. Wildey, and J. Wright. 2007. *Amended ballistic sand studies to provide low maintenance lead containment at active small arms firing range systems*. Technical Report ERDC TR-07-14. Vicksburg, MS: U.S. Army Engineer Research and Development Center.
- McKone, T. E., and R. L. Maddalena. 2007. *Plant uptake of organic pollutants from soil: A critical review of bioconcentration estimates based on models and experiments*. Report LBNL-60273. Berkeley, CA: Lawrence Berkeley National Laboratory.
- Zheng, C., and P. Wang. 1999. *MT3DMS: A modular three-dimensional multispecies transport model for simulation of advection, dispersion, and chemical reactions of contaminants in groundwater systems: Documentation and User's Guide*. Contract Report SERDP-99-01. Vicksburg, MS: U.S. Army Engineer Research and Development Center.

# REPORT DOCUMENTATION PAGE

**Form Approved  
OMB No. 0704-0188**

Public reporting burden for this collection of information is estimated to average 1 hour per response, including the time for reviewing instructions, searching existing data sources, gathering and maintaining the data needed, and completing and reviewing this collection of information. Send comments regarding this burden estimate or any other aspect of this collection of information, including suggestions for reducing this burden to Department of Defense, Washington Headquarters Services, Directorate for Information Operations and Reports (0704-0188), 1215 Jefferson Davis Highway, Suite 1204, Arlington, VA 22202-4302. Respondents should be aware that notwithstanding any other provision of law, no person shall be subject to any penalty for failing to comply with a collection of information if it does not display a currently valid OMB control number. **PLEASE DO NOT RETURN YOUR FORM TO THE ABOVE ADDRESS.**

|   |                                    |  |                                   |   |  |
|---|------------------------------------|--|-----------------------------------|---|--|
| <b>1. REPORT DATE (DD-MM-YYYY)</b><br>June 2013   |                                    | <b>2. REPORT TYPE</b><br>Final report        |                                   | <b>3. DATES COVERED (From - To)</b>   |  |
| <b>4. TITLE AND SUBTITLE</b><br>Modeling Firing Range Best Management Practices with TREECS™  |                                    |  |                                   | <b>5a. CONTRACT NUMBER</b>  |  |
|   |                                    |  |                                   | <b>5b. GRANT NUMBER</b>   |  |
|   |                                    |  |                                   | <b>5c. PROGRAM ELEMENT NUMBER</b>   |  |
| <b>6. AUTHOR(S)</b><br>Mark S. Dortch, Billy E. Johnson, and Jeffrey A. Gerald  |                                    |  |                                   | <b>5d. PROJECT NUMBER</b>   |  |
|   |                                    |  |                                   | <b>5e. TASK NUMBER</b>  |  |
|   |                                    |  |                                   | <b>5f. WORK UNIT NUMBER</b>   |  |
| <b>7. PERFORMING ORGANIZATION NAME(S) AND ADDRESS(ES)</b><br>Los Alamos Technical Associates, Inc.<br>999 Central Avenue, #300, Los Alamos, NM 87544;<br>U.S. Army Engineer Research and Development Center,<br>Environmental Laboratory, 3909 Halls Ferry Road,<br>Vicksburg, MS 39180-6199  |                                    |  |                                   | <b>8. PERFORMING ORGANIZATION REPORT NUMBER</b><br><br>ERDC/EL TR-13-6        |  |
| <b>9. SPONSORING / MONITORING AGENCY NAME(S) AND ADDRESS(ES)</b><br>U.S. Army Corps of Engineers<br>Washington, DC 20314-1000   |                                    |  |                                   | <b>10. SPONSOR/MONITOR'S ACRONYM(S)</b>                                       |  |
|   |                                    |  |                                   | <b>11. SPONSOR/MONITOR'S REPORT NUMBER(S)</b>                                 |  |
| <b>12. DISTRIBUTION / AVAILABILITY STATEMENT</b><br>Approved for public release; unlimited distribution.  |                                    |  |                                   |   |  |
| <b>13. SUPPLEMENTARY NOTES</b>  |                                    |  |                                   |   |  |
| <b>14. ABSTRACT</b><br>The Training Range Environmental Evaluation and Characterization System (TREECS™) is being developed for the Army with varying levels of capability to forecast the fate of and risk from munitions constituents (MC), such as high explosives (HE), within and transported from firing/training ranges to surface water and groundwater. The overall objective is to provide environmental specialists with tools to assess the potential for migration of MC into surface water and groundwater systems and to assess range management strategies to protect human and environmental health. TREECS™ can also be used to assess best management strategies (BMPs) for ranges to avoid, reduce, and remediate MC migration to receiving waters. This report describes how TREECS™ can be used to assess range BMPs. New TREECS™ modules are being developed to address some of the BMP assessments. The formulation, testing, and TREECS™ implementation strategies of these new modules are also presented in this report. |                                    |  |                                   |   |  |
| <b>15. SUBJECT TERMS</b><br>BMPs  |                                    | Modeling fate of munitions constituents (MC) |                                   | Training Range Environmental Evaluation and Characterization System (TREECS™) |  |
| <b>16. SECURITY CLASSIFICATION OF:</b>  |                                    |  | <b>17. LIMITATION OF ABSTRACT</b> | <b>18. NUMBER OF PAGES</b>  | <b>19a. NAME OF RESPONSIBLE PERSON</b>           |
| <b>a. REPORT</b><br>UNCLASSIFIED  | <b>b. ABSTRACT</b><br>UNCLASSIFIED | <b>c. THIS PAGE</b><br>UNCLASSIFIED          |                                   | 43  | <b>19b. TELEPHONE NUMBER (include area code)</b> |